

Heating a greenhouse

- 1 A greenhouse contains an electric heater.



- (a) The heater makes good use of the heating effect of an electric current.

Give an example of a device where the heating effect of an electric current is a **disadvantage**.

(1)

- (b) This label is attached to the heater.

230 V	500 W
50 Hz	

Use this information to calculate the expected current in the heater.

(3)

current = A

(c) Complete the sentence by putting a cross (☒) in the box next to your answer.

The potential difference across the heater can be measured either in volts or in

(1)

- A** amps per ohm
- B** amps per joule
- C** coulombs per ohm
- D** joules per coulomb

(d) When a charge flows in a resistor, the resistor becomes hot.

Explain why the resistor becomes hot.

(2)

.....

.....

.....

.....

- (e) A thermistor is used to control the heater.
The graph shows how the resistance of the thermistor changes with temperature.

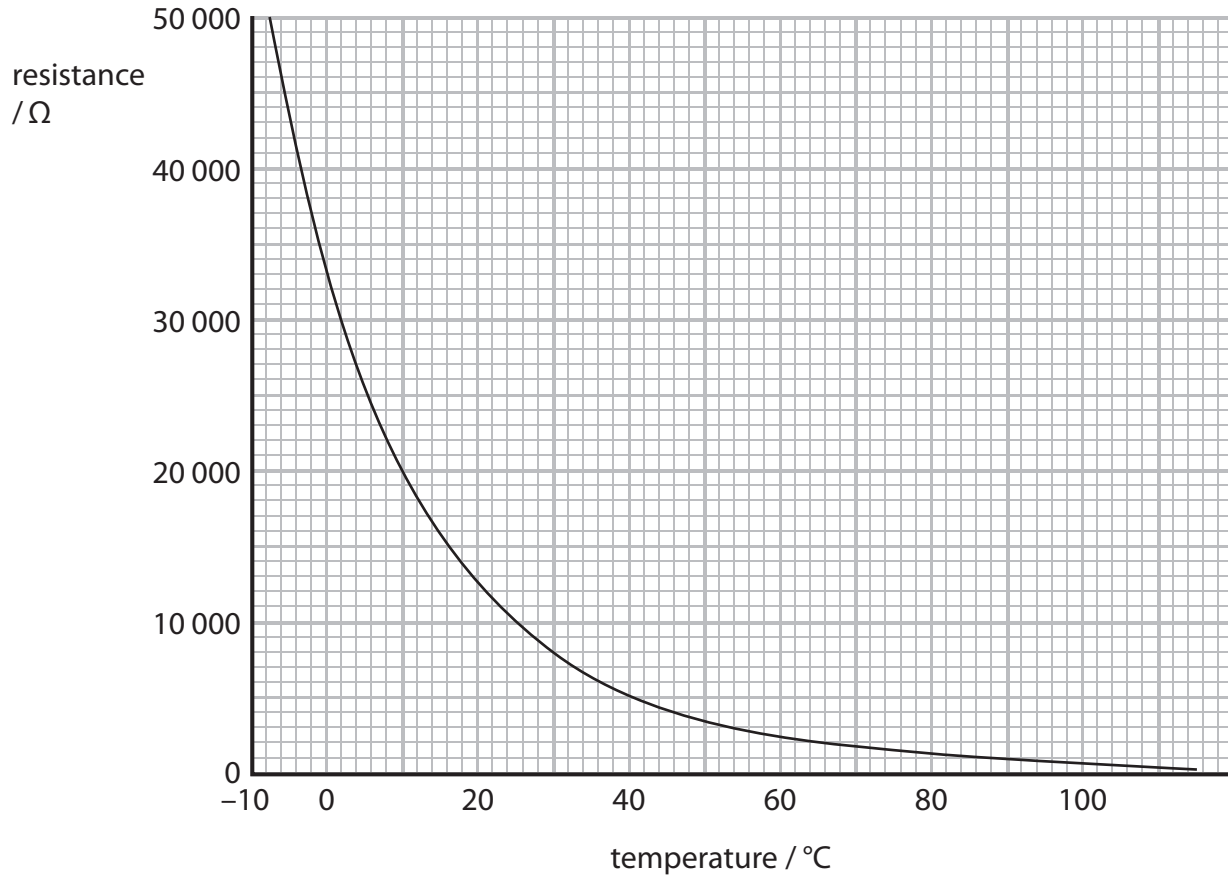

When the temperature is 10 °C, the current in the thermistor is 0.60 mA.

Calculate the potential difference across the thermistor at 10 °C.

(3)

potential difference = V

(Total for Question 3 = 10 marks)

Filament lamps

2 A student sets up an experiment to measure the potential difference (voltage) across a filament lamp.

She changes the current through the lamp.

The diagram shows the circuit she used.

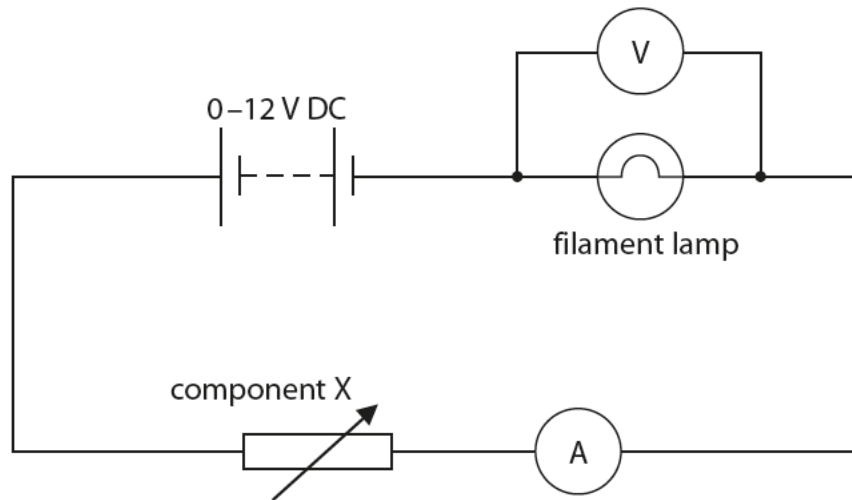

(a) Complete the sentences by putting a cross (☒) in the box next to your answer.

(i) The component X in the circuit diagram is a

(1)

- A diode
- B fixed resistor
- C thermistor
- D variable resistor

(ii) The meter that measures potential difference is

(1)

- A in parallel with the power supply
- B in parallel with the lamp
- C in series with the lamp
- D in series with the component X

(iii) Describe how the student should increase the current in the lamp.

(2)

.....

.....

.....

.....

(b) The student recorded these readings.

current / A	potential difference / V
0.00	0.0
0.20	2.0
0.31	4.0
0.37	6.0
0.42	8.0
0.44	10.0

Four points are plotted on the graph.

(i) Plot the points for 2.0 V and 8.0 V.

(1)

(ii) Draw the line of best fit.

(1)

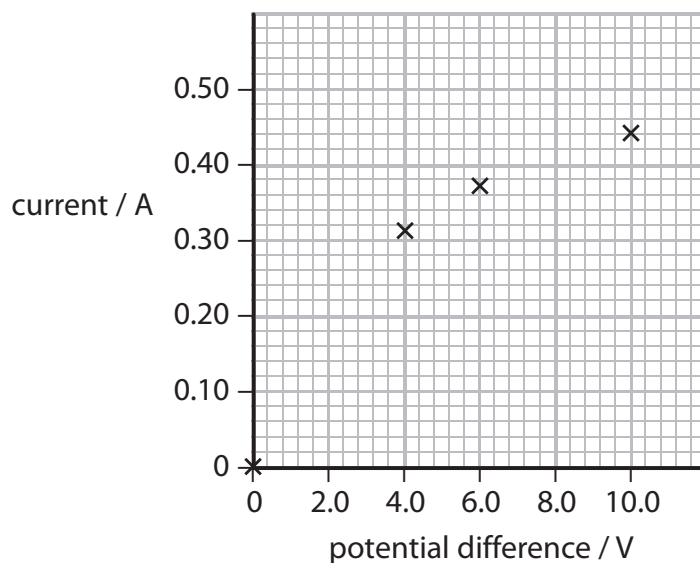

(c) Calculate the resistance of the lamp when the current is 0.44 A and the potential difference is 10.0 V.

(2)

$$R = \frac{V}{I}$$

resistance = Ω

(d) Describe the energy transfer that takes place in the lamp.

(2)

.....

.....

.....

.....

(Total for Question 3 = 10 marks)

Electric circuits

- 3 (a) The diagram shows an electric circuit with two resistors, R and S.

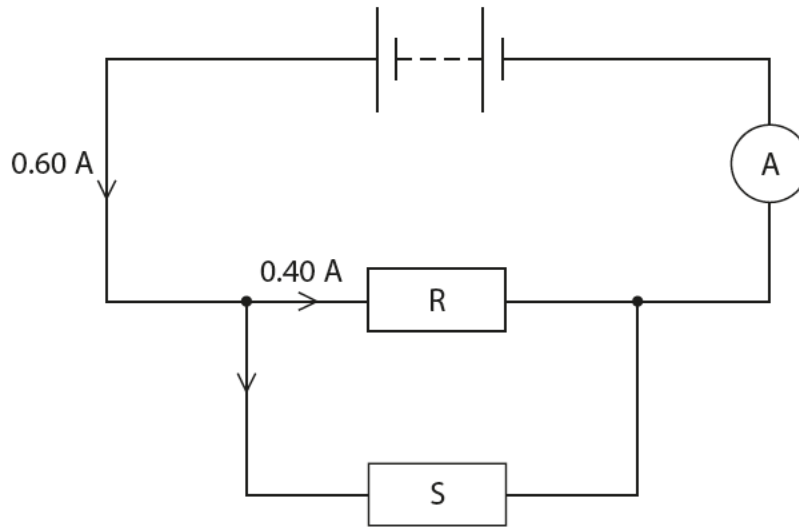

- (i) R has a resistance of 11 ohms.

Calculate the potential difference across R.

(2)

potential difference = V

(ii) Use information from the diagram to calculate the current in S.

(1)

current = A

(iii) Complete the sentence by putting a cross (☒) in the box next to your answer.

A student wants to measure the battery voltage with a voltmeter.

The voltmeter should be placed

(1)

- A** in series with the battery
- B** in parallel with the battery
- C** in parallel with the ammeter
- D** in series with either resistor R or S

(b) Explain why the temperature of a resistor increases when a current passes through it.

(2)

.....

.....

.....

.....

Electric circuits

- 4 (a) Some students investigate electric circuits.
They set up this circuit.

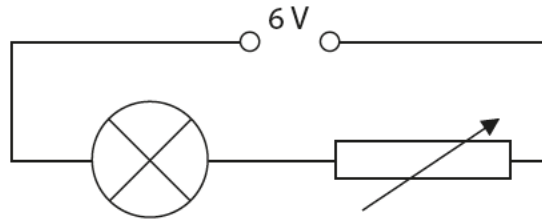

What can the students do to increase the brightness of the lamp?

Put a cross (☒) in the box next to your answer.

(1)

- A** add another lamp in series
- B** add another lamp in parallel
- C** increase the resistance of the variable resistor
- D** decrease the resistance of the variable resistor

- (b) The students want to measure both the current in the lamp and the potential difference (voltage) across the lamp.

- (i) Complete the circuit below with an ammeter and a voltmeter correctly connected.

The power supply, variable resistor and lamp symbols are already drawn for you.

(3)

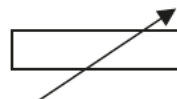
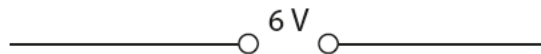

- (ii) The current in a lamp is 0.5 A.
Its resistance is 8 Ω .

Calculate the potential difference (voltage) across the lamp.

(2)

potential difference = V

- (c) Some electrical energy is transferred to light energy in the lamp.

Explain why only some of the electrical energy is transferred to light energy in the lamp.

(2)

.....

.....

.....

.....

- (d) The students use a different lamp in the circuit.
The current in this lamp is 0.4 A.
The potential difference (voltage) across the lamp is 5 V.

Calculate the power being supplied to the lamp.

(2)

power supplied to the lamp = W

(Total for Question 3 = 10 marks)

- 5 (a) Some students investigate the electrical resistance of different components using this circuit.

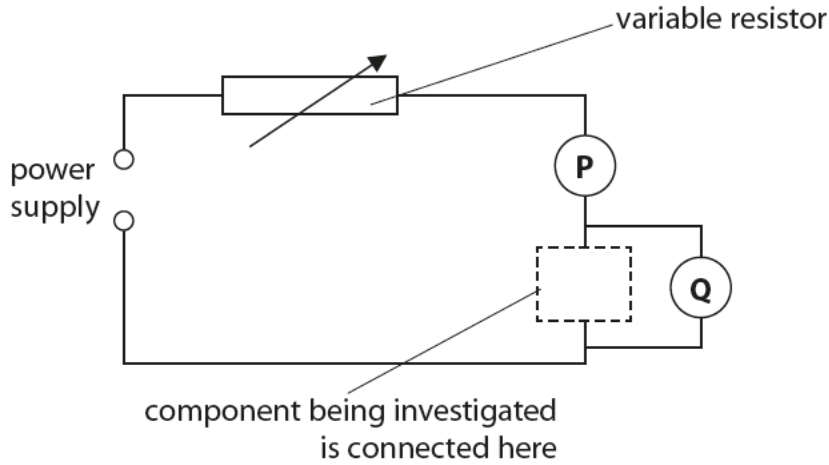

- (i) Which row of the table is correct for both meters **P** and **Q**?

Put a cross (☒) in the box next to your answer.

(1)

	meter P is	meter Q is
<input checked="" type="checkbox"/> A	an ammeter	an ammeter
<input checked="" type="checkbox"/> B	an ammeter	a voltmeter
<input checked="" type="checkbox"/> C	a voltmeter	a voltmeter
<input checked="" type="checkbox"/> D	a voltmeter	an ammeter

- (ii) One of the components being investigated is a 12 ohm resistor. When it is in the circuit, the ammeter reading is 0.50 A.

Calculate the voltmeter reading.

(2)

voltmeter reading = V

(iii) The students reduce the resistance of the variable resistor.
State what happens to the readings on each of the meters **P** and **Q**.

(2)

.....

.....

.....

.....

(iv) The students then reduce the voltage of the power supply.
State what happens to the current in the circuit.

(1)

.....

(b) The graphs **L**, **M** and **N** each show how the current in a component varies with the potential difference (voltage) across that component.

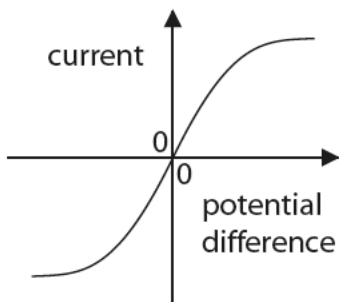

L

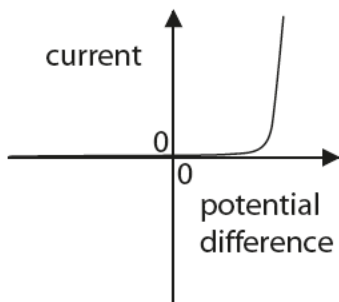

M

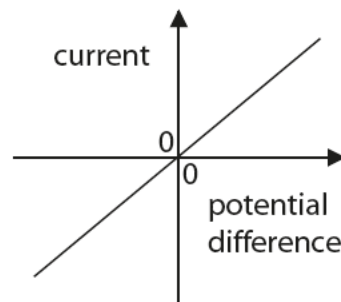

N

Match each graph with the symbol of the component to which it applies.
Draw lines to connect each symbol with its correct graph.

(2)

component symbol

graph

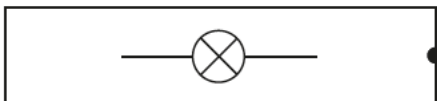

graph **L**

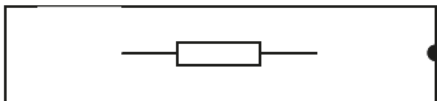

graph **M**

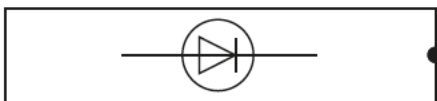

graph **N**

(Total for Question 1 = 8 marks)